

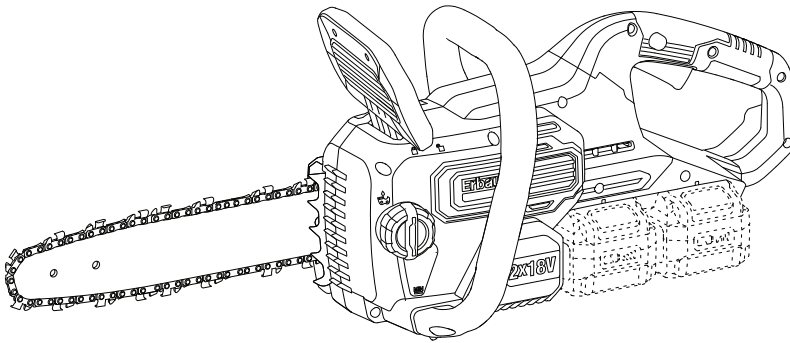

Erbauer



ECSG18-Li

EAN:3663602461982

ECSG3640-Li

EAN: XXXXXXXXXXXXXXX

ORIGINAL INSTRUCTIONS





Product description



Safety instructions



Assembly



Use



Care & maintenance



Guarantee



Declaration of conformity



WARNING! Please read all safety warnings carefully and be sure that they are fully understood before handling the tool.



PRODUCT DESCRIPTION

1. Sprocket wheel
2. Lubrication hole
3. Saw chain
4. Guide bar
5. Ridged bumper
6. Front hand guard
7. Front handle
8. Lock-off button
9. Rear handle
10. Switch trigger
11. Air inlets
12. Battery packs (x2) *
 - a. Release button*
 - b. Power bar button*
13. Air outlet
14. Oil level gauge
15. Chain oil tank cap
16. Guide bar cover
17. Drive sprocket cover
18. Chain tension knob
19. Clamping knob
20. Chain tensioning pin
21. Positioning pin
22. Thread hole
23. Drive sprocket
24. Fastening bolt
25. Oiling port
26. Chain direction indicator
27. Positioning hole



Parts marked with * are not included.



Product description

1

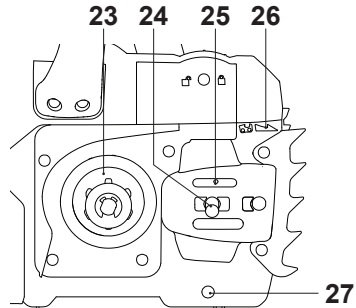
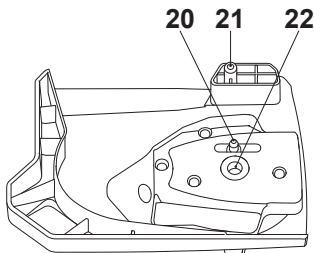
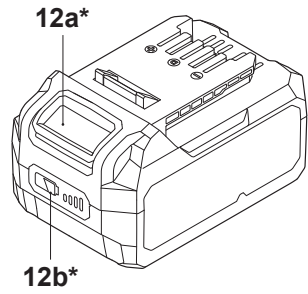
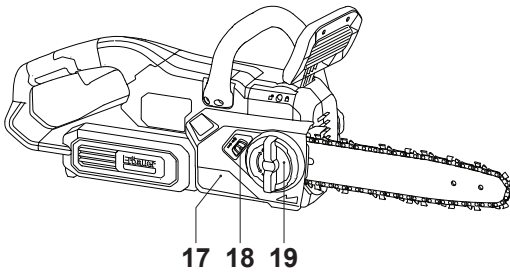
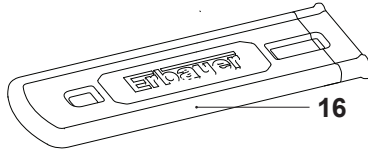
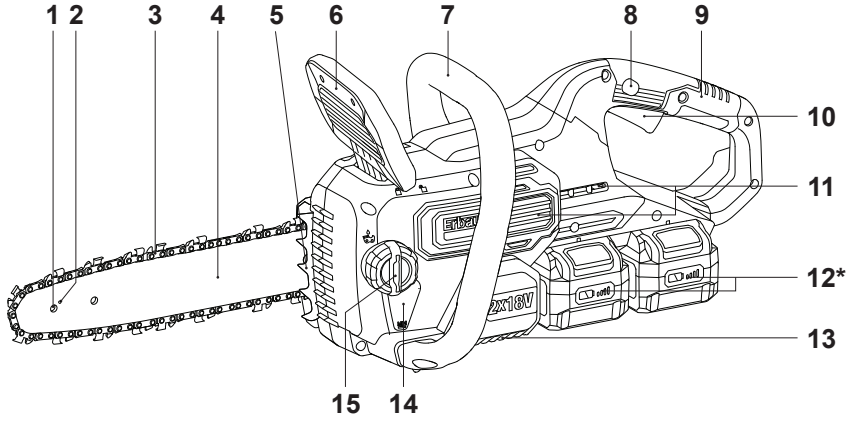

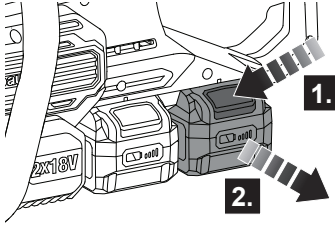
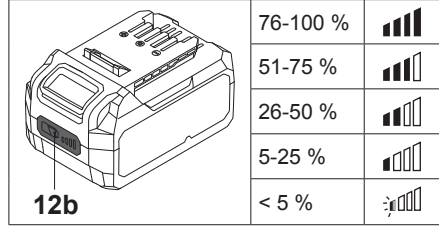
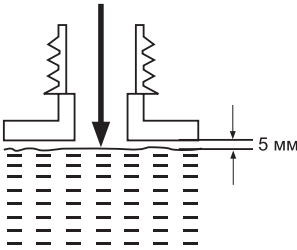
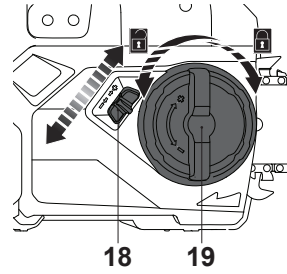
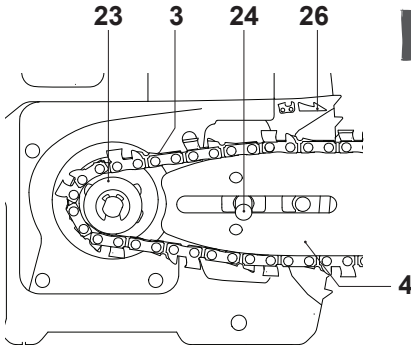
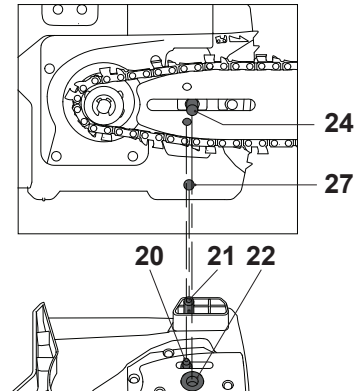
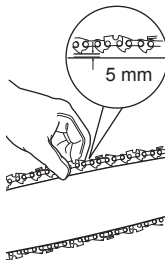
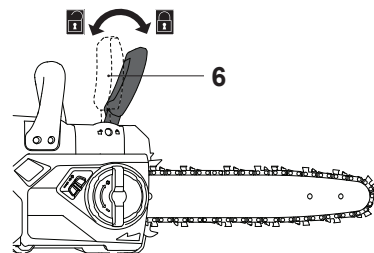
**A****B****C****D****E****F****G****H**



I

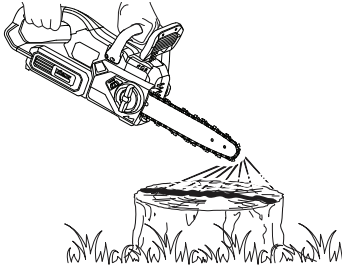

J

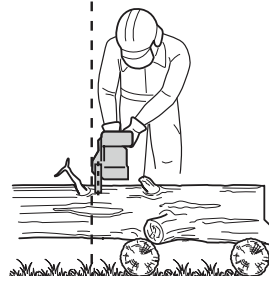

K

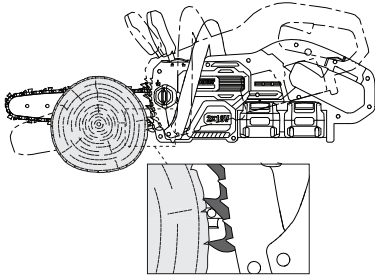

L

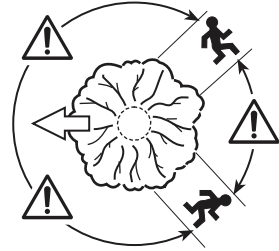

M

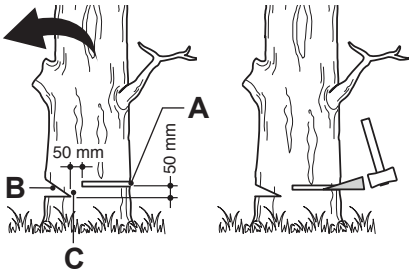

N

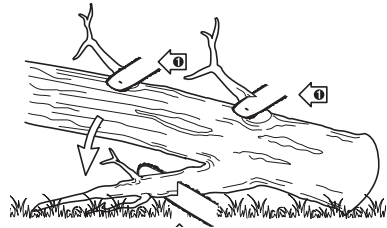

O



P

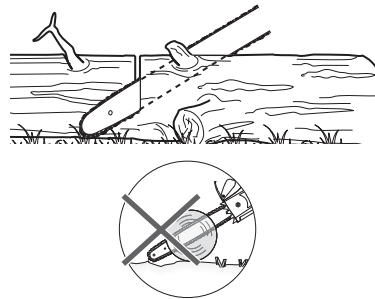



Q

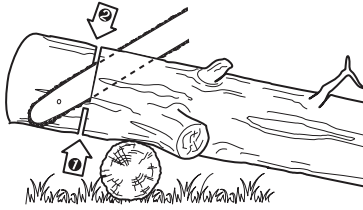

R

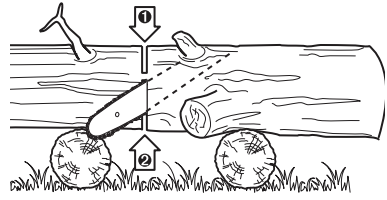

S

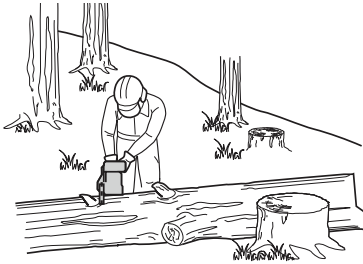

T

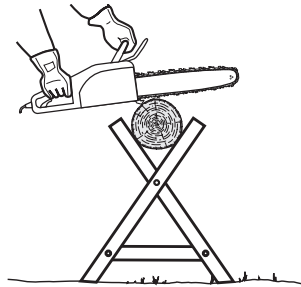

U

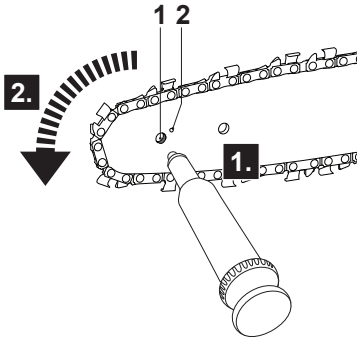

V

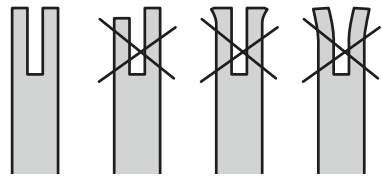



Safety instructions

GENERAL POWER TOOL SAFETY WARNING



WARNING Read all safety warnings, instructions, illustrations and specifications provided with this power tool. *Failure to follow all instructions listed below may result in electric shock, fire and/or serious injury.*

Save all warnings and instructions for future reference.

The term "power tool" in the warnings refers to your mains-operated (corded) power tool or battery-operated (cordless) power tool.

1) WORK AREA SAFETY

- a) **Keep work area clean and well lit.** *Cluttered or dark areas invite accidents.*
- b) **Do not operate power tools in explosive atmospheres, such as in the presence of flammable liquids, gases or dust.** *Power tools create sparks which may ignite the dust or fumes.*
- c) **Keep children and bystanders away while operating a power tool.** *Distractions can cause you to lose control.*

2) ELECTRICAL SAFETY

- a) **Power tool plugs must match the outlet. Never modify the plug in any way. Do not use any adapter plugs with earthed (grounded) power tools.** *Unmodified plugs and matching outlets will reduce risk of electric shock.*
- b) **Avoid body contact with earthed or grounded surfaces, such as pipes, radiators, ranges and refrigerators.** *There is an increased risk of electric shock if your body is earthed or grounded.*
- c) **Do not expose power tools to rain or wet conditions.** *Water entering a power tool will increase the risk of electric shock.*
- d) **Do not abuse the cord. Never use the cord for carrying, pulling or unplugging the power tool. Keep cord away from heat, oil, sharp edges or moving parts.** *Damaged or entangled cords increase the risk of electric shock.*
- e) **When operating a power tool outdoors, use an extension cord suitable for outdoor use.** *Use of a cord suitable for outdoor use reduces the risk of electric shock.*
- f) **If operating a power tool in a damp location is unavoidable, use a residual current device (RCD) protected supply.** *Use of an RCD reduces the risk of electric shock.*





3) PERSONAL SAFETY

- a) **Stay alert, watch what you are doing and use common sense when operating a power tool. Do not use a power tool while you are tired or under the influence of drugs, alcohol or medication. A moment of inattention while operating power tools may result in serious personal injury.**
- b) **Use personal protective equipment. Always wear eye protection. Protective equipment such as dust mask, non-skid safety shoes, hard hat, or hearing protection used for appropriate conditions will reduce personal injuries.**
- c) **Prevent unintentional starting. Ensure the switch is in the off-position before connecting to power source and/or battery pack, picking up or carrying the tool. Carrying power tools with your finger on the switch or energising power tools that have the switch on invites accidents.**
- d) **Remove any adjusting key or wrench before turning the power tool on. A wrench or a key left attached to a rotating part of the power tool may result in personal injury.**
- e) **Do not overreach. Keep proper footing and balance at all times. This enables better control of the power tool in unexpected situations.**
- f) **Dress properly. Do not wear loose clothing or jewellery. Keep your hair, clothing and gloves away from moving parts. Loose clothes, jewellery or long hair can be caught in moving parts.**
- g) **If devices are provided for the connection of dust extraction and collection facilities, ensure these are connected and properly used. Use of dust collection can reduce dust-related hazards.**
- h) **Do not let familiarity gained from frequent use of tools allow you to become complacent and ignore tool safety principles. A careless action can cause severe injury within a fraction of a second.**

4) POWER TOOL USE AND CARE

- a) **Do not force the power tool. Use the correct power tool for your application. The correct power tool will do the job better and safer at the rate for which it was designed.**
- b) **Do not use the power tool if the switch does not turn it on and off. Any power tool that cannot be controlled with the switch is dangerous and must be repaired.**
- c) **Disconnect the plug from the power source and/or remove the battery pack, if detachable, from the power tool before making any adjustments, changing accessories, or storing power tools. Such preventive safety measures reduce the risk of starting the power tool accidentally.**
- d) **Store idle power tools out of the reach of children and do not allow persons unfamiliar with the power tool or these instructions to operate the power tool. Power tools are dangerous in the hands of untrained users.**
- e) **Maintain power tools and accessories. Check for misalignment or binding of moving parts, breakage of parts and any other condition that may affect the power tool's operation. If damaged, have the power tool repaired before use. Many accidents are caused by poorly maintained power tools.**

- 
- 
- f) **Keep cutting tools sharp and clean.** *Properly maintained cutting tools with sharp cutting edges are less likely to bind and are easier to control.*
 - g) **Use the power tool, accessories and tool bits etc. in accordance with these instructions, taking into account the working conditions and the work to be performed.** *Use of the power tool for operations different from those intended could result in a hazardous situation.*
 - h) **Keep handles and grasping surfaces dry, clean and free from oil and grease.** *Slippery handles and grasping surfaces do not allow for safe handling and control of the tool in unexpected situations.*

5) BATTERY TOOL USE AND CARE

- a) **Recharge only with the charger specified by the manufacturer.** *A charger that is suitable for one type of battery pack may create a risk of fire when used with another battery pack.*
- b) **Use power tools only with specifically designated battery packs.** *Use of any other battery packs may create a risk of injury and fire.*
- c) **When battery pack is not in use, keep it away from other metal objects, like paper clips, coins, keys, nails, screws or other small metal objects that can make a connection from one terminal to another.** *Shorting the battery terminals together may cause burns or a fire.*
- d) **Under abusive conditions, liquid may be ejected from the battery; avoid contact. If contact accidentally occurs, flush with water. If liquid contacts eyes, additionally seek medical help.** *Liquid ejected from the battery may cause irritation or burns.*
- e) **Do not use a battery pack or tool that is damaged or modified.** *Damaged or modified batteries may exhibit unpredictable behaviour resulting in fire, explosion or risk of injury.*
- f) **Do not expose a battery pack or tool to fire or excessive temperature.** *Exposure to fire or temperature above 130 °C may cause explosion.*
- g) **Follow all charging instructions and do not charge the battery pack or tool outside the temperature range specified in the instructions.** *Charging improperly or at temperatures outside the specified range may damage the battery and increase the risk of fire.*

6) SERVICE

- a) **Have your power tool serviced by a qualified repair person using only identical replacement parts.** *This will ensure that the safety of the power tool is maintained.*
- b) **Never service damaged battery packs.** *Service of battery packs should only be performed by the manufacturer or authorized service providers.*

CHAIN SAW SAFETY WARNINGS

- **Keep all parts of the body away from the saw chain when the chain saw is operating. Before you start the chain saw, make sure the saw chain is not contacting anything.** *A moment of inattention while operating chain saws may cause entanglement of your clothing or body with the saw chain.*

- **Always hold the chain saw with your right hand on the rear handle and your left hand on the front handle.** *Holding the chain saw with a reversed hand configuration increases the risk of personal injury and should never be done.*
- **Hold the power tool by insulated gripping surfaces only, because the saw chain may contact hidden wiring.** *Saw chains contacting a “live” wire may make exposed metal parts of the power tool “live” and could give the operator an electric shock.*
- **Wear safety glasses and hearing protection. Further protective equipment for head, hands, legs and feet is recommended.** *Adequate protective clothing will reduce personal injury by flying debris or accidental contact with the saw chain.*
- **Do not operate a chain saw in a tree.** *Operation of a chain saw while up in a tree may result in personal injury.*
- **Always keep proper footing and operate the chain saw only when standing on fixed, secure and level surface.** *Slippery or unstable surfaces such as ladders may cause a loss of balance or control of the chain saw.*
- **When cutting a limb that is under tension be alert for spring back.** *When the tension in the wood fibres is released the spring loaded limb may strike the operator and/or throw the chain saw out of control.*
- **Use extreme caution when cutting brush and saplings.** *The slender material may catch the saw chain and be whipped toward you or pull you off balance.*
- **Carry the chain saw by the front handle with the chain saw switched off and away from your body. When transporting or storing the chain saw always fit the guide bar cover.** *Proper handling of the chain saw will reduce the likelihood of accidental contact with the moving saw chain.*
- **Follow instructions for lubricating, chain tensioning and changing accessories.** *Improperly tensioned or lubricated chain may either break or increase the chance for kickback.*
- **Keep handles dry, clean, and free from oil and grease.** *Greasy, oily handles are slippery causing loss of control.*
- **Cut wood only. Do not use chain saw for purposes not intended. For example: do not use chain saw for cutting plastic, masonry or non-wood building materials.** *Use of the chain saw for operations different than intended could result in a hazardous situation.*

Causes and operator prevention of kickback:

Kickback may occur when the nose or tip of the guide bar touches an object, or when the wood closes in and pinches the saw chain in the cut.

Tip contact in some cases may cause a sudden reverse reaction, kicking the guide bar up and back towards the operator.

Pinching the saw chain along the top of the guide bar may push the guide bar rapidly back towards the operator.

Either of these reactions may cause you to lose control of the saw which could result in serious personal injury. Do not rely exclusively upon the safety devices built into your saw. As a chain saw user, you should take several steps to keep your cutting jobs free from accident or injury.



Kickback is the result of tool misuse and/or incorrect operating procedures or conditions and can be avoided by taking proper precautions as given below:

- **Maintain a firm grip, with thumbs and fingers encircling the chain saw handles, with both hands on the saw and position your body and arm to allow you to resist kickback forces.** *Kickback forces can be controlled by the operator, if proper precautions are taken. Do not let go of the chain saw.*
- **Do not overreach and do not cut above shoulder height.** *This helps prevent unintended tip contact and enables better control of the chain saw in unexpected situations.*
- **Only use replacement bars and chains specified by the manufacturer.** *Incorrect replacement bars and chains may cause chain breakage and/or kickback.*
- **Follow the manufacturer's sharpening and maintenance instructions for the saw chain.** *Decreasing the depth gauge height can lead to increased kickback.*

ADDITIONAL SAFETY WARNINGS FOR CHAIN SAW OPERATION

- Always remove the battery pack before assembling, adjusting or cleaning, and before leaving the machine unattended for any period.
- Checking the completeness, assembly and setting of the chain saw (see details below) before start to work. Repeat the checking regularly during your work.
- It is recommended that the unexperienced user should have practical instruction in the use of the chainsaw and the protective equipment from an experienced operator. The initial practice should be cutting logs on a saw horse or cradle.
- Children and juveniles, with the exception of apprentices older than 16 years and under supervision, may not operate the chain saw. The same applies for persons who do not or do not sufficiently know how to handle the chain saw.
- The operating instructions should always be ready to hand. Persons unfit or tired must not operate the chain saw.
- Wait until the chain has come to a standstill completely before placing it down.
- Ensure that the air vents are always unobstructed and clear. Clean them if necessary with a soft brush. Blocked air vents may lead to overheating and damage the product.
- Switch the product off immediately if you are disturbed while working by other people entering the working area.
- Do not overwork yourself. Take regular breaks to ensure you can concentrate on the work and have full control over the product.
- Never work with the tip of the chain.



BATTERY PACK SAFETY WARNINGS

- **Ensure the switch is in the off position before inserting battery pack.** Inserting the battery pack into machines that have the switch on can cause accidents.
- **Use only original battery packs intended specifically for this machine.** Use of any other battery packs may create a risk of injury and fire.
- **Do not open the battery.** Danger of short-circuiting.
- **Protect the battery against heat (e. g., against continuous intense sunlight and fire) water and moisture.** Danger of explosion.
- **In case of damage and improper use of the battery, vapours may be emitted. Ventilate the area and seek medical help in case of complaints.** The vapours can irritate the respiratory system.
- **Use the battery pack only in conjunction with this product and/or product family.** This measure alone protects the battery against dangerous overload.
- **The battery can be damaged by pointed objects such as nails or screwdrivers or by force applied externally.** An internal short circuit can occur and the battery can burn, smoke, explode or overheat.
- **Do not short-circuit the battery.** There is danger of explosion.
- Use the battery only within a temperature range between 0 °C and 40 °C. As an example, do not leave the battery in the car in summer.
- If you intend to store a battery for a period without use then store the battery at room temperature (19 °C to 25 °C), charged to approx. 30 – 50% of capacity. When storing for very long periods boost charge the battery once per year to prevent over-discharge.
- Occasionally clean the venting slots and contact pins of the battery pack using a soft, clean and dry brush.

VIBRATION AND NOISE REDUCTION

To reduce the impact of noise and vibration emission, limit the time of operation, use low-vibration and low-noise operating modes as well as wear personal protective equipment.

Take the following points into account to minimise the vibration and noise exposure risks:

1. Only use the product as intended by its design and these instructions.
2. Ensure that the product is in good condition and well maintained.
3. Use correct attachments for the product and ensure they are in good condition.
4. Keep tight grip on the handles/grip surface.
5. Maintain this product in accordance with these instructions and keep it well lubricated (where appropriate).
6. Plan your work schedule to spread any high vibration tool use across a longer period of time.
7. Prolonged use of the product exposes the user to vibrations that can cause a range of conditions collectively known as hand-arm vibration syndrome (HAVS) e.g. fingers going white; as well as specific diseases such as carpal tunnel syndrome. To reduce this risk when using the product, always wear protective gloves and keep your hands warm.

EMERGENCY

Familiarise yourself with the use of this product by means of this instruction manual. Memorise the safety directions and follow them to the letter. This will help to prevent risks and hazards.

- a) Always be alert when using this product, so that you can recognise and handle risks early. Fast intervention can prevent serious injury and damage to property.
- b) Switch off and remove the battery pack if there are malfunctions. Have the power tool checked by a qualified professional and repaired, if necessary, before you operate it again.

RESIDUAL RISKS

Even if you are operating this product in accordance with all the safety requirements, potential risks of injury and damage remain. The following dangers can arise in connection with the structure and design of this product:

1. Health defects resulting from vibration emission if the product is being used over long periods of time or not adequately managed and properly maintained.
2. Injuries and damage to property due to broken attachments or the sudden impact of hidden objects during use.
3. Danger of injury and property damage caused by flying objects or poor power tool accessories.



WARNING! This product produces an electromagnetic field during operation! This field may under some circumstances interfere with active or passive medical implants! To reduce the risk of serious or fatal injury, we recommend persons with medical implants to consult their doctor and the medical implant manufacturer before operating this product!



Assembly

01 Unpacking

1. Unpack all parts and lay them on a flat, stable surface.
2. Remove all packing materials and shipping devices, if applicable.
3. Make sure the delivery contents are complete and free of any damage. If you find that parts are missing or show damage do not use the product but contact your dealer. Using an incomplete or damaged product represents a hazard to people and property.
4. Ensure that you have all the accessories and tools needed for assembly and operation. This also includes suitable personal protective equipment.



WARNING! The product must be fully assembled before operation! Do not use a product that is only partly assembled or assembled with damaged parts!



Wear protective gloves for this assembly work and always lay the product on a flat and stable surface while assembling.

Follow the assembly instructions step-by-step and use the pictures provided as a visual guide to easily assemble the product!



Do not insert the battery pack before the power tool is completely assembled!



WARNING! The product and the packaging are not children's toys! Children must not play with plastic bags, sheets and small parts! There is a danger of choking and suffocation!

02 Battery pack



2 battery packs of same type as specified in this instruction manual shall be used for the product. Always attach or remove the 2 battery packs at the same time. The product cannot work with one battery pack.

Attaching (Fig. A)

Slide 2 battery packs into the compartments under rear handle one by one until each of them is securely locked in position.

Removing (Fig. A)

Depress the battery pack release button (12a) and pull the battery pack out of the power tool.



WARNING! Remove the battery pack before assembly, cleaning, adjustments, maintenance, storage and transportation.



Checking battery capacity (Fig. B)

The Li-Ion battery pack (12) is equipped with a power bar (12b) which is used to give an indication of the battery pack's remaining capacity. Press the power bar button (12b) to check battery capacity as Fig. B. The LED will stay lit for approximately 5 seconds.

Charging

The battery may require charging before first use. Only charge with the correct Erbauer charger

Please refer to the charger instruction manual for details about the charging process.

03 Chain lubrication oil



WARNING! The product is not filled with chain oil. It is essential to fill the product with chain oil before using it! Never operate the product without chain oil as this will result in extensive damage to the product! Operating the saw chain dry or with too little chain oil will decrease cutting efficiency, shorten the product life span and cause rapid wear to the saw chain and guide bar from overheating!

Insufficient chain oil is evident by smoke or bar discoloration!

Adequate lubrication of the saw chain during cutting operations is essential to minimize friction with the guide bar!

Fill chain oil immediately when the oil level is below "Min"-indicator on the oil level gauge (14).

1. Position the product in a way that the chain oil tank cap (15) faces upwards.
2. Open the cap and check the oil level. Fill the tank with chain lubrication oil if the oil level is more than 2 cm below the inside edge of the tank. We recommend using environment-friendly biodegradable chain oil specifically intended to be used with chain saw. Never use recycled/old oil. Use of non-approved oil will invalidate the warranty.
3. Do not overfill and leave approx. 5 mm space between the oil level and the inside edge of the tank to allow for expansion (Fig. C).
4. Tighten the cap firmly.

04 Guide bar and saw chain



WARNING! Use only the guide bar and saw chain according which is defined in the technical data. Do not insert battery pack before the chain saw is completely assembled. Always wear protective gloves!

Attaching guide bar and saw chain

1. Loosen the clamping knob (19) anticlockwise and remove the drive sprocket cover (17, Fig. D).
2. Turn the chain tension knob (18) so that the chain tensioning pin (20) moves towards the drive sprocket (23) all the way to the stop.

- 
3. Fit the saw chain (3) around the guide bar (4) and then over the drive sprocket. Make sure that the guide bar is correctly positioned over the fastening bolt (24) and the saw chain 'Cutter' complies with the chain direction indicator (26) on the plastic housing (Fig. E).
 4. Attach the drive sprocket cover (17) to the housing so that the holes/pins and fastening bolt (24)/thread hole (22) are aligned with each other properly (Fig. F). Turn the clamping knob clockwise so that the guide bar can still move.

Saw chain tensioning



WARNING! Always check the saw chain tension before use, after the first cuts and regularly during use. Upon initial operation, new chains can lengthen considerably. This is normal during the break-in period and the interval between future adjustments will lengthen quickly.

Always maintain proper chain tension! A loose chain increases the risk of kickback! A loose chain may jump out of the guide bar groove! This may injure the operator and damage the chain! A loose chain will cause rapid wear to the chain, guide bar and sprocket!

Tensioning the chain too tightly will overload the motor and cause damage, and insufficient tension can cause chain derailing, whereas a correctly tightened chain provides the best cutting characteristics and prolonged working life! The chain life mainly depends upon sufficient lubrication and correct tensioning!

1. Place the product on a suitable flat surface.
2. Lift up the tip of the guide bar (4) and keep it slight lifted as you adjust the tension. Ensure that the guide bar has some movement; loosen the clamping knob (19) slightly if necessary.
3. Turn the chain tension knob (18) until all chain sections are just touching the bottom edge of the guide.
4. Check the chain tension using one hand, by pulling upwards on the chain against the weight of the product. The correct chain tension is achieved when the saw chain can be lifted by approx. 5 mm from the guide bar in the centre (Fig. G).
5. Re-adjust the tension as described above if you find that the chain saw is too loose or tight.
6. Pull the saw chain along the upper side of the guide bar by hand (WITH PROTECTIVE GLOVE) from one end to the other several times. The chain should feel tight but still move freely.
7. Tighten the clamping knob firmly to fix the guide bar.

05 Guide bar cover

Always fit the guide bar cover to guide bar when the product is not in use, e.g. refilling of chain oil, inserting/removing of battery packs, storage and transportation. Remove the guide bar cover before operation.



Use

Intended use

The product is intended for cutting wood logs and limbs. It must not be used for cutting other materials, such as plastic, stone, metal, wood that contains foreign objects, or materials that are harmful to health. This product should not be used outside of domestic premises e.g. for felling trees or lumber work in forested areas.

The product may only be used with the guide bar/saw chain combination stated within these instructions. The use of other types or sizes is not allowed. With this product vertical and horizontal cuts can be performed. Longitudinal sections may only be cut by professionals.

For safety reasons it is essential to read the entire instruction manual before first operation and to observe all the instructions therein. This product is intended for private domestic use only, not for any commercial use. It must not be used for any purposes other than those described.

Before you start

01 Protection



Controls



01 Switching on/off

Hold the chain saw as in working condition. To start the machine, press the lock-off button (8) and then press the switch trigger (10) and keep it pressed. To switch off the machine, release the On/Off switch.

02 Kickback brake (Fig. H)

The kickback brake is a safety mechanism activated through the front hand guard (6) when kickback occurs. The saw chain stops immediately.

The following function check should be carried out before each use and at regular intervals:

1. Switch the product on.
2. While the motor is running, engage the kickback brake to position  by rolling your left hand forward against the front hand guard (6). Saw chain (3) and motor should stop immediately.
3. Release the switch trigger and try to switch the product on.
4. The saw chain and motor shall not start.
5. Release the switch trigger and pull front hand guard backwards to position  after function check.

Operation



WARNING! In some countries regulations define at what time of the day and on what special days products are allowed to be used and what restrictions apply! Ask your community for detailed information and observe the regulations in order to preserve a peaceful neighbourhood and avoid committing administrative offences.

01 Checking chain lubrication (Fig. I)

The chain oil level and lubrication should be checked after everything else is ready before cutting.

1. Check oil level with the oil level gauge (14). Refill chain oil if necessary.
2. Start the machine; keep it running and check if the chain oil is delivered as shown in Fig. I.

02 General cutting process (Fig. J, K)

1. To become proficient attend a recognised chain saw training course to learn how to operate chain saws safely and effectively. Familiarise yourself with all the controls and switches. Practise all movements with the product switched off.
2. Always hold the product firmly with both hands. Front handle with the left hand and rear handle with the right hand. Fully grip both handles at all times during operation. Never operate the product using only one hand.
3. Only use the product with a secure stance. Hold the product at the right-hand side of your body.
4. Ensure that cutting object does not exceed the usable cutting length of the chain saw. The tip of guide bar shall always be kept at least 5 cm outside the outline of the wood log.
5. Ensure the saw chain is running at full speed before it makes contact with the wood. Use the ridged bumper (5) to secure the product onto the wood before starting to cut and use it as a leverage point while cutting.



6. Reset the ridged bumper at a low point when cutting thicker logs by pulling the product slightly backwards and reposition at lower level to continue sawing. Do not remove the product completely from the wood.
7. Do not force the saw chain while cutting, let the chain do the work.
8. Do not operate the product with arms fully extended or attempt to saw areas which are difficult to reach, or on a ladder. Never use the product above shoulder height.
9. Optimum sawing is achieved if the chain speed remains constant during cutting.
10. Be careful when reaching the end of the cut. The weight of the product may change unexpectedly as it cuts free from the wood. This can cause accidents to the legs and feet. Always remove the product from a wood cut while the product is running.
11. Check the chain tension and oil feeding regularly.

03 Felling a tree (Fig. L, M)

1. When bucking and felling operations are being performed by two or more persons at the same time, the felling operations should be separated from the bucking operation by a distance of at least twice the height of the tree being felled. Trees should not be felled in a manner that would endanger any person, strike any utility line or cause any property damage. If the tree does make contact with any utility line, the company should be notified immediately.
2. The product operator should keep on the uphill side of the terrain as the tree is likely to roll or slide downhill after it is felled.
3. An escape path should be planned and cleared as necessary before cuts are started. The escape path should extend back and diagonally to the rear of the expected line of fall.
4. Before felling is started, consider the natural lean of the tree, the location of larger branches and the wind direction to judge which way the tree will fall.
5. Remove dirt, stones, loose bark, nails, staples and wire from the tree.

Notching undercut and felling back cut

Make the notch (B) $\frac{1}{3}$ the diameter of the tree, perpendicular to the direction of falls. Make the lower horizontal notching cut first. This will help to avoid pinching either the saw chain or the guide bar when the second notch is being made.

Make the felling back cut (A) at least 50 mm higher than the horizontal notching cut.

Keep the felling back cut parallel to the horizontal notching cut. Make the felling back cut so enough wood is left to act as a hinge. The hinge (C) wood keeps the tree from twisting and falling in the wrong direction. Do not cut through the hinge.

As the felling gets close to the hinge, the tree should begin to fall. If there is any chance that the tree may not fall in desired direction or it may rock back and bind the saw chain, stop cutting before the felling back cut is complete and use wedges of wood, plastic or aluminum to open the cut and drop the tree along the desired line of fall.

When the tree begins to fall remove the product from the cut, switch off and put the product down then use the retreat path planned. Be alert for overhead limbs falling and watch your footing.



04 Limbing and pruning (Fig. N)

Limbing is removing the branches from a fallen tree. When limbing leave larger lower limbs to support the log off the ground. Remove the small limbs in one cut. Branches under tension should be cut from the bottom up to avoid binding the product.

05 Cutting spring poles (Fig. O)

A spring pole is any log, branch, rooted stump, or sapling which is bent under tension by other wood so that it springs back if the wood holding it is cut or removed. On a fallen tree, a rooted stump has a high potential of springing back to the upright position during the bucking cut to separate the log from the stump. Watch out for spring poles, they are dangerous.

06 Bucking a log (Fig. P, Q, R, S, T)

1. Follow the simple directions for easy cutting. When the log is supported along its entire length, it is cut from the top (overbuck, Fig. P).
2. When the log is supported on one end, cut 1/3 the diameter from the underside (underbuck). Then make the finished cut by overbucking to meet the first cut (Fig. Q).
3. When the log is supported on both ends, cut 1/3 the diameter from the top (overbuck). Then make the finished cut by underbucking the lower 2/3 to meet the first cut (Fig. R).
4. When bucking on a slope always stand on the uphill side of the log. When “cutting through”, to maintain complete control release the cutting pressure near the end of the cut without relaxing your grip on the product handles. Do not let the chain contact the ground. After completing the cut, wait for the saw chain to stop before you move the product. Always switch off the product before moving from tree to tree (Fig. S).
5. Support small logs on a sawing stand or another log while bucking (Fig. T).

After use

1. Switch the product off and remove battery packs.
2. Check, clean and store the product as described below.



+



Care & maintenance



WARNING! Switch the product off and remove the battery pack to disconnect from the power supply before assembly, cleaning, adjustments, maintenance, storage and transportation.



Only perform care and maintenance work according to these instructions! All further works must be performed by a qualified specialist!

1. Keep the product clean. Remove debris from it after each use and before storage.
2. Regular and proper cleaning will help ensure safe use and prolong the life of the product.
3. Inspect the product before each use for worn and damaged parts. Do not operate it if you find broken and worn parts.

Clean

1. Clean the product with a dry cloth. Use a brush for areas that are hard to reach.
2. In particular clean the air inlet (11) and the space under drive sprocket cover (17) after every use with a cloth and brush.
3. Check for worn or damaged parts. Replace worn parts as necessary or contact an authorised service centre for repair before using the product again.



Do not use chemical, alkaline, abrasive or other aggressive detergents or disinfectants to clean this product as they might be harmful to its surfaces.

Maintenance

01 Sprocket wheel



NOTE: It is not necessary to remove the saw chain to lubricate the sprocket wheel. Lubrication can be done on the job.

- 
1. Clean the sprocket wheel.
 2. Using a disposable lube gun, insert the needle nose into the lubrication hole and inject grease until it appears at the outside edge of the sprocket wheel (Fig. U step 1).
 3. Rotate the saw chain by hand (WITH PROTECTIVE GLOVE) (Fig. U step 2).
Repeat the lubrication procedure until the entire sprocket wheel has been greased.

02 Guide bar and saw chain

Most guide bar problems can be prevented merely by keeping the product well maintained. Incorrect filling and non-standard cutter and depth gauge settings are the causes of most guide bar problems, primarily resulting in uneven bar wear. As the bar wears unevenly, the rails widen, which may cause the chain to clatter and make it difficult to complete straight cuts. If the guide bar is insufficiently lubricated and the product is operated with a saw chain which is too tight, this will contribute to rapid bar wear. To help minimise bar wear, maintenance of the guide bar as well as the saw chain is recommended.

1. Disassemble the guide bar and saw chain in reversed order from assembly.
2. Check the oiling port for clogging and clean if necessary to ensure proper lubrication of the guide bar and saw chain during operation. Use a soft wire small enough to insert into the oil discharge hole.
3. Check the drive sprocket. If it is worn or damaged due to strain, have it replaced by an authorised service centre or a similarly qualified person.
4. Clear residue from the rails on the guide bar using a screwdriver, putty knife, wire brush or other similar tool. This will keep the oil passages open to provide proper lubrication to the guide bar and saw chain.
5. Check the guide bar 'rail' for wear: Hold a ruler (straight edge) against the side of the guide bar and 'cutter side plates'. If there is a gap between the ruler and guide bar the guide bar 'rail' is normal. If there is no gap (ruler flush against the side of the guide bar) the guide bar 'rail' is worn and needs to be replaced with a new one of the same type (Fig. V).
6. Check the saw chain for possible wear and damages. Replace it with a new one if required. Experienced users can sharpen a dull saw chain (see chapter "Saw chain sharpening").

03 Saw chain sharpening



NOTE: Saw chain sharpening may be required:

- after damp wood is cut;
- when handling the product becomes difficult (pulls to the left or right);
- when the saw chain is blunt (excessive force is required to penetrate the wood), or obviously damaged;
- Never saw with a blunt chain. The saw chain is blunt if you have to push the product into the tree and the chips are very small.

Have your saw chain sharpened professionally at an authorised service centre or sharpen the chain yourself.



WARNING! Only sharpen the saw chain yourself if you are trained and have experience! Use proper tools to sharpen the saw chain!

Transportation

1. Switch the product off and remove the battery packs.
2. Clean the product.
3. Attach the guide bar cover.
4. Always carry the product by its handle.
5. Protect the product from any heavy impact or strong vibrations which may occur during transportation in vehicles.
6. Secure the product to prevent it from slipping or falling over.

Storage

1. Switch the product off and remove the battery packs.
2. Clean the product.
3. Attach the guide bar cover.
4. Clean the product and empty the oil tank.
5. Store the product and its accessories in a dark, dry, frost-free, well-ventilated place.
6. Always store the product in a place that is inaccessible to children. The ideal storage temperature is between 10°C and 30°C.
7. We recommend using the original package for storage or covering the product with a suitable cloth or enclosure to protect it against dust.

Troubleshooting

Suspected malfunctions are often ones that the users can fix themselves. Therefore check the product using this section. In most cases the problem can be solved quickly.



WARNING! Only perform the steps described within these instructions! All further inspection, maintenance and repair work must be performed by an authorised service centre or a similarly qualified specialist if you cannot solve the problem yourself!

Problem	Possible cause	Solution
1. Product does not start	1.1. Battery pack not properly attached 1.2. Battery pack discharged 1.3. Battery pack damaged 1.4. Kickback brake is active 1.5. Other electrical defect to the product	1.1. Attach properly 1.2. Remove and charge battery pack 1.3. Check by a specialist electrician 1.4. Pull front hand guard backwards 1.5. Check by a specialist electrician
2. Product does not reach full power	2.1. Battery pack capacity too low 2.2. Lubrication oil is empty 2.3. Saw chain tension too high 2.4. Air vents are blocked	2.1. Charge battery pack 2.2. Check and add oil 2.3. Adjust saw chain tension 2.4. Clean the air vents
3. Cutting result is unsatisfactory	3.1. Working tool is dull / damaged	3.1. Replace with a new one
4. Vibration or noise is excessive	4.1. Guide bar or saw chain not properly assembled 4.2. Working tool is dull / damaged	4.1. Refer to chapter "Tube assembly" 4.2. Replace with a new one
5. Product suddenly stops	5.1. Battery pack discharged 5.2. Battery packs too hot	5.1. Remove and charge battery pack 5.2. Remove battery packs and let it cool down

Recycling and disposal



Waste electrical products should not be disposed of with household waste. Please recycle where facilities exist. Check with your local authority or local store for recycling advice.

Disposal of an exhausted battery pack

Batteries and battery packs should not be disposed of with household waste. To preserve natural resources, please recycle or dispose of the battery pack properly. Consult your local waste authority for information regarding available recycling and/or disposal options. Discharge your battery pack by operating your tool, then remove the battery pack from the tool and cover the battery pack connections with heavy duty adhesive tape to prevent short circuit and energy discharge. Do not attempt to open or remove any of the components.



Guarantee

This product carries a guarantee of 24 months starting from the day of purchase. Please retain your receipt as a proof.

This guarantee specifically excludes losses due to:

- Normal wear and tear, including accessory wear
- Overload, misuse or neglect
- Failure of consumable items (such as batteries)
- Repairs attempted by anyone other than an authorized agent
- Accidental damage caused by foreign objects or substances
- Lack of routine maintenance
- Failure to follow manufacturer's guidelines
- Loss of use of the goods

Due to continuous product improvement, we reserve the right to change the product specification without prior notice.

This guarantee does not affect your statutory rights.

For any inquiries relating to the guarantee please contact your retailer: If you purchased this product in B&Q store or website then call 0333 0143101. If you bought this product in SFX outlet or website then call 03330 112 112.

01 TECHNICAL SPECIFICATIONS

Product model	: ECSG18-Li	ECSG3640-Li
Rated voltage	: 36 V d.c. (18V x 2)	36 V d.c. (18V x 2)
Chain speed (no-load)	: 12 m/s	12 m/s
Cutting length	: 28 cm	37.5 cm
Saw chain type	: 90PX045	90PX056X
Guide bar type	: 124MLEA041	164MLEA041
Guide bar length	: 352 mm	458 mm
Chain oil tank volume	: 150 ml	150 ml
Weight	: 3.5 kg	3.8 kg
Sound pressure level L_{pA}	: 80.56 dB(A)	80 dB(A)
Uncertainty K_{pA}	: 1.87 dB(A)	1.87 dB(A)
Guaranteed Sound power level L_{WA}	: 104 dB(A)	104 dB(A)
Uncertainty K_{WA}	: 1.87 dB(A)	3.38 dB(A)
Vibration a_h for main handle	: 5.534 m/s ²	3.366 m/s ²
Vibration a_h for auxiliary handle	: 3.028 m/s ²	1.556 m/s ²
Uncertainty K	: 1.5 m/s ²	1.5 m/s ²

Ambient temperature range for tool and battery use: 0°C to 40°C

The product shall be used together with battery pack (2x) and charger as below:

Battery pack model	: EBAT18-Li-2 / EBAT18-Li-4 / EBAT18-Li-5 / EHPB18-Li-4 / EHPB18-Li-8 (sold separately)
Charger model	: EC18-Li / EFC18-Li / EMC18-Li (sold separately)

The sound values have been determined according to noise test code given in EN 60745-2-13.

The sound intensity level for the operator may exceed 80 dB(A) and ear protection measures are necessary.

The declared vibration value has been measured in accordance with a standard test method (according to EN 60745-2-13) and may be used for comparing one product with another. The declared vibration value may also be used in a preliminary assessment of exposure.



WARNING! The vibration emission value during actual use of the tool can differ from the declared value depending on the ways in which the tool is used. Identify safety measures to protect the operator that are based on an estimation of exposure in the actual conditions of use (taking account of all parts of the operating cycle such as the times when the tool is switched off and when it is running idle in addition to the trigger time). Depending on the actual use of the product the vibration values can differ from the declared total. Adopt proper measures to protect yourself against vibration exposures. Take the whole work process including times the product is running under no load or switched off into consideration. Proper measures include among others regular maintenance and care of the product and accessories, keeping hands warm, periodical breaks and proper planning of work processes.

Rating label explanation

ECSG18-Li = Model number
 E = Erbauer
 CSG = Chain Saw
 18 = 18 V d.c.
 Li = Lithium Ion

ECSG3640-Li = Model number
 E = Erbauer
 CSG = Chain Saw
 3640 = 36/40 V d.c.
 Li = Lithium Ion

02 SYMBOLS

On the product, the rating label and within these instructions you will find among others the following symbols and abbreviations. Familiarize yourself with them to reduce hazards like personal injuries and damage to property.



Always wear eye protection.



Always wear ear protection.



Wear a dust mask.



Wear protective gloves.



Wear safety helmet



Wear face protection



Wear safety footwear



Correct direction of cutting teeth



Lock / to tighten or secure.



Unlock / to loosen.



Note / Remark.



Caution / Warning.

dB(A)

Decibel (A-rated)

n_0

No-load speed



Do not expose the product to rain or wet conditions (moisture).



To reduce the risk of injury, user must read instruction manual.



Switch the product off and disconnect it from the power supply before assembly, cleaning, adjustments, maintenance, storage and transportation.



Kickback! Tip contact may cause the guide bar to move suddenly upward and backwards what may cause serious injury to user.



Contact of the guide bar tip with any object should be avoided.



Always use the product with two hands. Do not use one hand when operating the product.



Objects thrown by the product could hit the user or other bystanders. Always ensure that other people and pets remain at a safe distance from the product when it is in operation. In general, children must not come near the area where the product is.



The product complies with the applicable European directives and an evaluation method of conformity for these directives was done.



WEEE symbol. Waste electrical products should not be disposed of with household waste. Please recycle where facilities exist. Check with your Local Authority or local store for recycling advice.



Batteries and battery packs should not be disposed of with household waste. Please recycle where facilities exist. Check with your Local Authority or local store for recycling advice.



Guaranteed sound power level



Do not dispose of battery packs in rivers or immerse in water.



Do not dispose of battery packs in fire. They will explode and cause injury.



Do not expose battery packs to heat in excess of 40°C. Do not charge or store the battery pack in temperatures below 0°C (32°F) and above 40°C (104°F).

yyWxx

Manufacturing date code; year of manufacturing (20yy) and week of manufacturing (Wxx)





Manufacturer, Fabricant, Producent, Producător, Fabricante:

UK Manufacturer:
Kingfisher International Products Limited
3 Sheldon Square London, W2 6PX
United Kingdom
www.kingfisher.com/products

EU Manufacturer:
Kingfisher International Products B.V.
Rapenburgerstraat 175E
1011 VM Amsterdam
The Netherlands
www.kingfisher.com/products

EN	www.diy.com www.screwfix.com www.screwfix.ie	To view instruction manuals online, visit www.kingfisher.com/products
FR	www.castorama.fr www.bricodepot.com	Pour consulter les manuels d'instructions en ligne, rendez-vous sur le site www.kingfisher.com/products
PL	www.castorama.pl	Aby zapoznać się z instrukcją obsługi online, odwiedź stronę www.kingfisher.com/products
ES	www.bricodepot.es	Para consultar los manuales de instrucciones en línea, visite www.kingfisher.com/products
PT	www.bricodepot.pt	Para consultar manuais de instruções online, visite www.kingfisher.com/products
RO	www.bricodepot.ro	Pentru a consulta manualele de instrucțiuni online, vizitați www.kingfisher.com/products
TR	www.koctas.com.tr	Kullanım kılavuzuna internet üzerinden ulaşmak için www.kingfisher.com/products adresini ziyaret edin